

IMPROVING THE RELIABILITY OF POWER SUPPLY SYSTEMS

Toyirov Muhridin Zoir o'g'li

Tashkent Institute of irrigation and agricultural mechanization engineers

National research university student of Bukhara Institute of Natural

Resources Management.

Email: toirovmuhridin82@gmail.com

Annotation: The article considers the possibility of improving the reliability of power supply systems. It has proposed to use sectioning devices - reclosers for organizing ATS and AR, under voltage protection, overcurrent protection, protection against single-phase earth faults, and connection of new consumers. The level of reliability and quality of power supply of the distribution network assessed, which is carried out according to the indicative indicators SAIFI, SAIDI, RNRE and ARAE, which characterize, respectively, the number and duration of outages in the network for the period under review, the relative efficiency of reconstruction and the average efficiency of the use of reclosers.

Keywords: recloser, sectioning, reliability of power supply, disconnection of consumers, reliability indicators, automatic reclosing.

Introduction

The low reliability of power supply to remote consumers, the presence of sites in a wooded area, frequent damage and a long search time in overhead distribution electrical networks of medium voltage class (6, 10, 35 kV) lead to the need to switch to networks of a new technological order with qualitatively new reliability characteristics, efficiency and manageability [1]. In accordance with the regulation of PJSC Rosseti "On a unified technical policy in the electric grid complex", the program for the innovative development of the electric grid complex provides for the introduction of technologies based on intelligent switching devices - reclosers that use integrated connection controllers and the ability to integrate into a single information system control [2].

The use of reclosers makes it possible to localize emergency sections of networks and restore power supply to consumers in undamaged sections of the network by automatically sectioning and redundant overhead power lines. Each individual sectioning device is an intelligent device that analyzes the operating modes of the electrical network and automatically reconfigures it in emergency modes. The effect is achieved by reducing the time of power supply interruption and the number of consumer disconnections in case of unstable damage, automating the process of localizing the damaged area and using completely maintenance-free equipment. Evaluation of the effectiveness of the implemented network reconstruction is carried

out according to the methodology for calculating reliability indicators (indices SAIFI, SAIDI, etc.).

Statement of the purpose and objectives of the study. The aim of the work was to determine the effectiveness of using reclosers for a given network scheme in the Simulink MATLAB modeling environment. In the course of the work, the following tasks were set and solved:

1) An analysis and selection of a methodology for calculating the efficiency indicators of network reconstruction carried out.

2) Models for calculating the efficiency indicators of the use of reclosers for a certain network scheme in the Simulink MATLAB modeling environment developed.

3) A comparative analysis of the results of the reliability indicators of the reconstructed feeder before and after the installation of reclosers made.

The object of study in this work was the methodology for calculating the efficiency indicators of network reconstruction, and the subject of the study was the reliability indicators taken as the main ones in the SMART GRID concept: SAIFI, SAIDI, RNRE and ARAE.

Research results. Algorithm for calculating reliability indicators. The reliability indicators taken as the main ones in the SMART GRID concept are the so-called. Indices SAIFI, SAIDI. SAIFI characterizes the average number of emergencies per year, leading to disruptions in the power supply. SAIFI reliability indicator - (System Average Interruption Frequency Index - the average frequency of occurrence of damage in the system) - characterizes the average number of consumer outages per year [3],

$$SAIFI = \frac{\sum(\omega_i \cdot N_i)}{\sum N_i}, \quad (1)$$

where ω_i – number of consumer disconnections, i - th feeder section, off/year;

N_i – number of consumers i - th section of the feeder, pcs.

i – number of feeder sections, pcs.

$$\omega_i = 0,01 \cdot \omega_0 \cdot (1 - k_{HY})L \quad (2)$$

where ω_0 – specific frequency of damages per 100 km of the line, off/year;

k_{HY} – coefficient taking into account the presence of multiple automatic reclosing (AR) to eliminate unstable faults in the network: $k_{mc} = 0$ if there is no AR;

$k_{HY} = 0.6$ in the presence of a single AR; $k_{mc} = 0.8$ with double AR;

L_i – the total length of the feeder sections, in case of damage on which the consumers of the i -th section are disconnected, km;

$$\omega_0 = n \cdot 100 / L \quad (3)$$

where n – number of feeder disconnections per year, off/year;

L – line length, km.

Reliability indicator *SAIDI* – (*System Average Interruption Duration Index*– average outage duration) - characterizes the average duration of one outage in the system per year, [h / year] [3],

$$SAIDI = \Sigma(T_i \cdot N_i) / \Sigma N_i, \quad (4)$$

where T_i – time of interruption of power supply to consumers of the i -th section of the feeder, h/year,

$$T_i = \omega_i \cdot T \cdot k_{ic}, \quad (5)$$

where T – average recovery time of one stable damage, h;

k_{ic} – the coefficient taking into account the effect of reducing the search area for a damaged area due to sectioning on the total time for restoring power supply, in the presence of automatic sectioning points, is taken equal to $k_{ic} = 0,6$.

$$T = T_{beg} \cdot n_{off} \quad (6)$$

where T_{beg} – total time of power supply interruption in case of feeder emergency shutdowns, [h/year];

n_{off} – number of feeder outages leading to interruption of power supply, [off./year].

To assess the effect of network reconstruction, additional reliability indices introduced, such as RNRE (relative network reconstruction efficiency) and ARAE (average recloser application efficiency) indices.

RNRE - relative efficiency of network reconstruction calculated by the formula (7): $RNRE = 1 - SAIFI/SAIFI$ (7)

where SAIFI (0), SAIFI – the average number of steady-state faults per year per consumer before and after network automation, respectively.

The RNRE index characterizes how much the SAIFI index has improved after reconstruction compared to the situation before reconstruction.

ARAE – average efficiency of using reclosers [5]:

$$ARAE = RNRE \cdot F/R \quad (8)$$

where F – the number of feeders included in the reconstructed network, R – the number of installed reclosers in the reconstructed network.

Calculation of reliability indicators. The methodology for calculating the reliability indicators of the SAIFI and SAIDI network before and after the installation of reclosers worked out using the example of a ring feeder. To improve the reliability of power supply to consumers, it planned to install sectional reclosers and organize double automatic reclosing and undervoltage protection (MVN) on the head switches of the feeder [3-6]. Diagrams of the ring feeder before and after the installation of reclosers shown in Figure 1 [6].a)

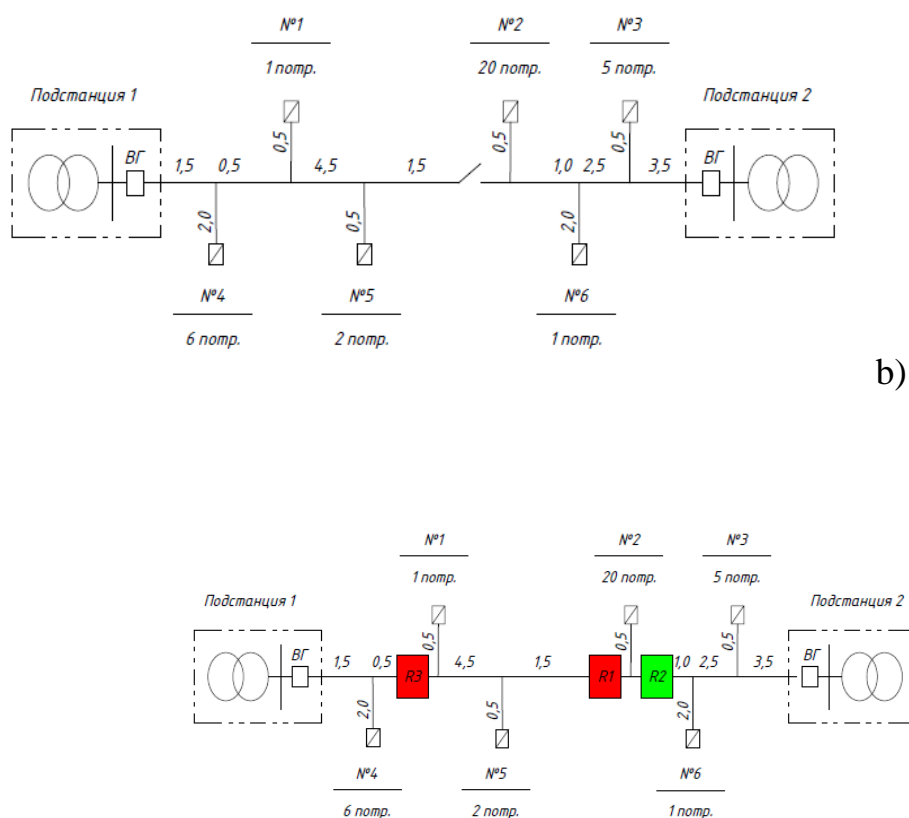

Figure 1– a) - Scheme of the ring feeder before the installation of reclosers: №1, №4, №5 – numbers of consumers of line 1 from substation 1; No. 2, No. 3, No. 6 - numbers of taps of line 2 from substation 2; b) - ring feeder diagram after installation of reclosers: R1, R2, R3 - reclosers.

Table 1 shows the lengths of the feeder sections, the numbers and the number of consumers receiving power from substations 1 and 2.

Table 1

Section lengths, numbers and number of consumers in sections [6]

Sector number, consumer numbers	The number of consumers N , pcs	Section length, km
1, №4	$N1 = 6$	$L1 = 1,5 + 0,5 + 2,0 = 4$
2, №1, №5	$N2 = 1 + 2 = 3$	$L2 = 0,5 + 4,5 + 1,5 + 0,5 = 7$
3, №2	$N3 = 20$	$L3 = 0,5$
4, №3, №6	$N4 = 1 + 5 = 6$	$L4 = 1,0 + 2,0 + 2,5 + 0,5 + 3,5 = 9,5$
	$N\Sigma = 35$	$L\Sigma = 20$

The values of the specific frequency of damage per 100 km of the line per year on the first feeder was 24, on the second 37, the average recovery time for one stable damage on the first and second feeders was the same - 6 hours. To calculate the reliability indicators, the feeder is divided into sections (1, 2, 3, 4), as shown in Figure 2.

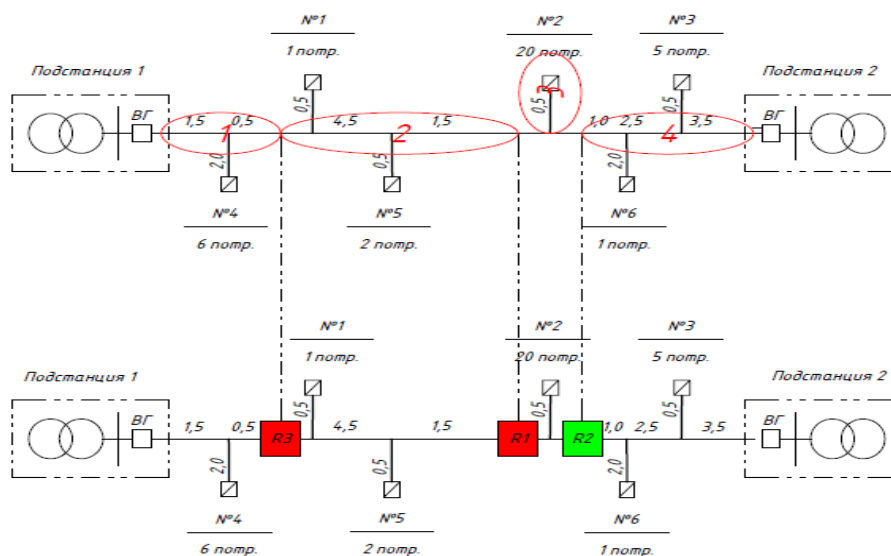

Figure 2. Scheme of the ring feeder with division into sections 1-4

Rationale for the choice of coefficients k_{mc} and k_{ic} when calculating the quantities ω_i or T_i before installing reclosers:

- on the sector 1 or 2 $k_{mc} = 0,6$, because the head switch has a one-time automatic reclosure and, according to statistics, reduces the number of consumer disconnections in case of unstable damage by 60%;

- coefficient $k_{ic} = 1$ due to the lack of partitioning.

Rationale for the choice of coefficients k_{mc} or k_{ic} when calculating the quantities ω_i or T_i after installation of reclosers:

- coefficient $k_{mc} = 0,8$, because on the main switch and reclosers there is a two-fold automatic reclosure and, according to statistics, reduces the number of consumer disconnections in case of unstable damage by 80%;

- coefficient $k_{ic} = 0,6$ due to the reduction of the search area for the damaged area due to sectioning.

In addition, Figure 4 shows a model for calculating the RNRE and ARAE indicators after installing reclosers in the Simulink MATLAB environment:

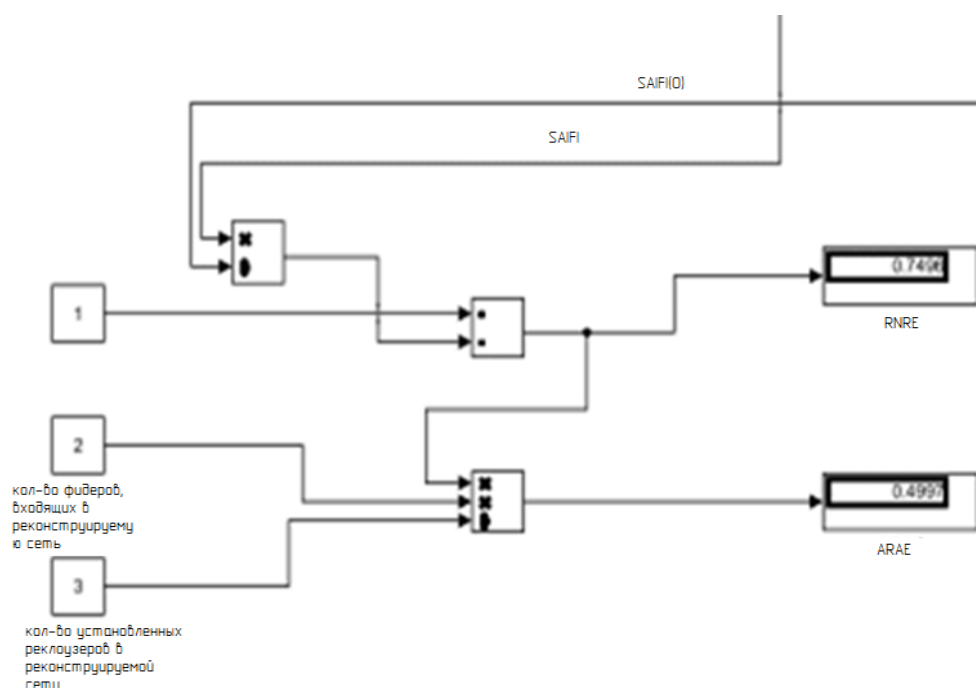

Figure 4 - Model for calculating the RNRE and ARAE indicators after installing reclosers in the Simulink MATLAB environment

Calculation results

Table 2

Comparative analysis of SAIFI and SAIDI feeder performance before and after installation of reclosers

SAIFI indicators Number of consumer disconnections, off / year		SAIDI metrics The duration of consumer outages, h / year	
before installation recloser	after installation recloser	before recloser installation	after installation recloser

3,311	0,2303	19,87	0,829
-------	--------	-------	-------

Таблица 3

Feeder RNRE and ARAE after reconstruction

RNRE Relative efficiency of network reconstruction	ARAE Average efficiency of reclosers
0,7496	0,4997

Conclusion

1. The use of intelligent sectional devices - reclosers in medium voltage distribution rural networks aimed at ensuring decentralized automation and network manageability, improving the reliability and quality of power supply.

2. Partitioning devices – reclosers and it is advisable to use in the network for organizing ATS and AR, under voltage protection, overcurrent protection, protection against single-phase earth faults, and connection of new consumers.

3. The assessment of the level of reliability and quality of power supply of the distribution network is carried out according to the indicative indicators SAIFI, SAIDI, RNRE and ARAE, Which characterize, respectively, the number and duration of outages in the network for the period under review, the relative efficiency of reconstruction and the average efficiency of the use of reclosers.

4. Thus, because of the installation of reclosers in the feeder under study, there is a significant decrease in SAIFI = 0.2303 off/year and SAIDI = 0.829 h / year. The calculated data obtained indicate a significant reduction in the number and duration of power supply interruptions to consumers by 14.37 and 23.96 times, respectively. Analysis of the RNRE index showed that the relative reconstruction of the network under consideration is 75%, and the average efficiency of using reclosers in terms of ARAE is 50%.

References:

1. Habibovich, A. N. (2022). Determination of the cross-sectional area of the threshold between rows of cotton.
2. Абдуалиев Н. Х., Умирзоков Ж., ХАкимов К. З. Внедрение устройства для образования продольного пала с оснащённого уплотнительным катком при междурядьях хлопчатника //наука и инновации в ххi веке: актуальные вопросы, открытия и достижения. – 2022. – С. 50-53.
3. Содиков, М. А. (2021). КРАТКИЙ АНАЛИЗ ТВЕРДЕНИЯ БЕТОНА И ЖЕЛЕЗОБЕТОНА ТРАДИЦИОННЫМИ МЕТОДАМИ. НАУКА И ОБРАЗОВАНИЕ В СОВРЕМЕННОМ ОБЩЕСТВЕ 3, 31.

4. Usmanov F. B., Sadikov M. A. The rationale for the use of flat reflectors in the heat treatment of concrete //Ученый XXI века. – 2020. – №. 12-1 (71). – С. 13-16.
5. Isayev S. X., Qodirov Z. Z., Oripov I. O., & Bobirova M. B. (2022). EFFECTS OF RESOURCEEFFICIENT IRRIGATION TECHNOLOGIES IN IRRIGATION OF SUNFLOWERS ON LAND HYDROGEOLOGICAL CONDITIONS. *British Journal of Global Ecology and Sustainable Development*, 4, 95–100. Retrieved from <https://journalzone.org/index.php/bjgesd/article/view/55>
6. Egamberdiyev, M. S., Oripov, I. U., Hakimov, S., Akmalov, M. G., Gadoyev, A. U., & Asadov, H. B. (2022). Hydrolysis during hydration of anhydrous calcium sulfosilicate. *Eurasian Journal of Engineering and Technology*, 4, 76-81.
7. Egamberdiev, M. S., Oripov, I. U., & Sh, T. S. (2022). Development of a Method for Measuring the Layered Moisture State of Concrete and Various Bases. *Eurasian Journal of Engineering and Technology*, 4, 82-84.
8. Qodirov, Z. Z., Oripov, I. A., Tagiyev, A., Shomurodova, G., & Bobirova, M. (2022). WATERSAVING IRRIGATION TECHNOLOGIES IN SOYBEAN IRRIGATION, EFFECT OF SOYBEAN ON GROWTH AND DEVELOPMENT. *European Journal of Interdisciplinary Research and Development*, 3, 79-84.
9. Qodirov, Z. Z., Oripov, I. O., & Sh, A. (2022). Effect of Drip Irrigation of Sunflower Crop on Soil Meliorative Status. *Texas Journal of Agriculture and Biological Sciences*, 8, 107-111.
10. Khodirov Z, Jumaev J, & Oripov I. (2023). Application of water-saving irrigation technologies in the irrigation of fodder beets grown as the main crop. *Texas Journal of Agriculture and Biological Sciences*, 17, 34–39. Retrieved from <https://zienjournals.com/index.php/tjabs/article/view/4137>